



US00D605782S

(12) **United States Design Patent**
Ross

(10) **Patent No.:** **US D605,782 S**

(45) **Date of Patent:** **** Dec. 8, 2009**

(54) **AIRCRAFT SHELTER**

(57) **CLAIM**

(76) Inventor: **James M. Ross**, 8511 E. Hillsdale,
Orange, CA (US) 92869

I claim the ornamental design for an aircraft shelter, as shown
and described.

(**) Term: **14 Years**

DESCRIPTION

(21) Appl. No.: **29/289,113**

FIG. 1 is a perspective view of an aircraft shelter, illustrated
with a canopy in a lowered position, showing my new design;
FIG. 2 is a right-side elevational view thereof, illustrated with
the canopy in the lowered position, the left-side elevational
view being a mirror image thereof;

(22) Filed: **Jul. 7, 2007**

(51) **LOC (9) Cl.** **25-02**

(52) **U.S. Cl.** **D25/56**

(58) **Field of Classification Search** D25/56;
D12/401; 135/901, 87; 52/3, 4, 5, 79.6,
52/23, 66; 160/19, 29, 38, 39

FIG. 3 is a right-side elevational view thereof, illustrated with
the canopy in a raised position, the left-side elevational view
being a mirror image thereof,

See application file for complete search history.

FIG. 4 is a front elevational view thereof, illustrated with the
canopy in the lowered position;

(56) **References Cited**

U.S. PATENT DOCUMENTS

D211,519 S	6/1968	Caminker	
D274,157 S *	6/1984	Freeland	D25/56
D274,653 S	7/1984	Peiren	
D409,763 S *	5/1999	Rogers et al.	D25/56
6,360,492 B1 *	3/2002	Ross	52/66
6,505,638 B1 *	1/2003	Powell et al.	135/124

FIG. 5 is a rear elevational view thereof, illustrated with the
canopy in the lowered position;

FIG. 6 is a bottom plan view thereof, illustrated with the
canopy in the lowered position;

FIG. 7 is a top plan view thereof, illustrated with the canopy
in the lowered position; and,

FIG. 8 is a top plan view thereof, illustrated with the canopy
in the raised position.

* cited by examiner

The description of my design is an open-sided, roofed structure
for the protection of aircraft fuselages, or other items
with wide protrusions.

Primary Examiner—Doris Clark

(74) *Attorney, Agent, or Firm*—QuickPatents, Inc.; Kevin
Prince

1 Claim, 3 Drawing Sheets

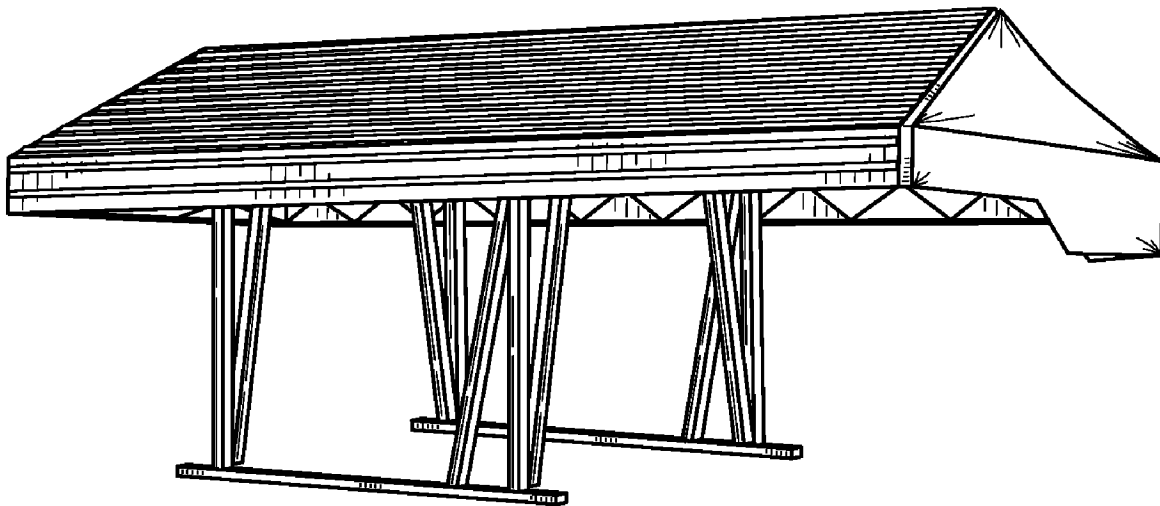

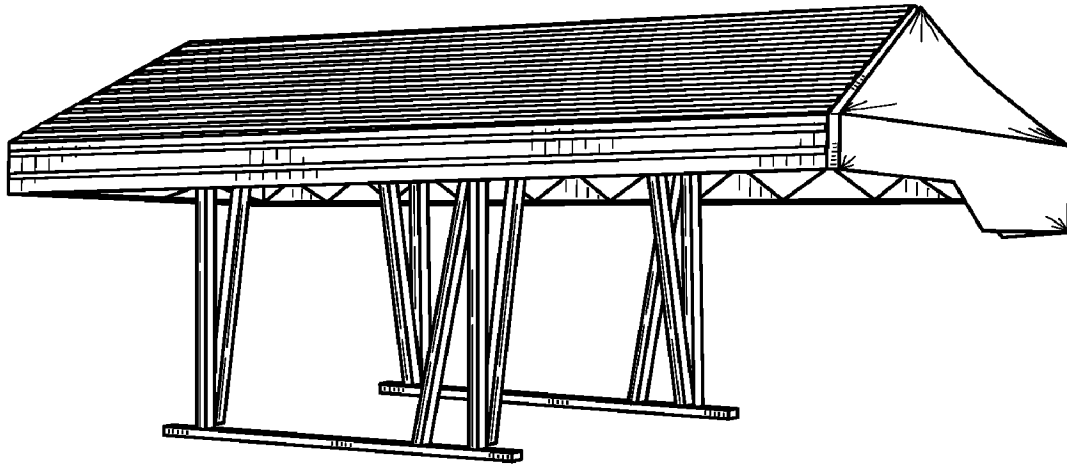

FIG. 1

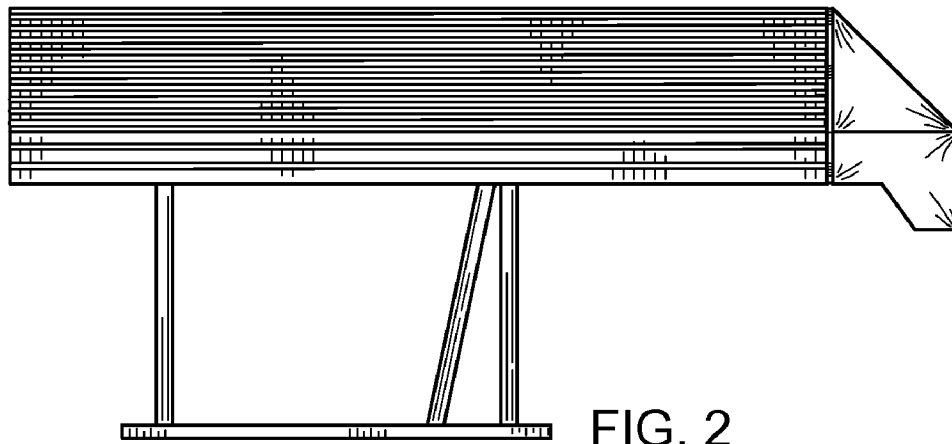

FIG. 2

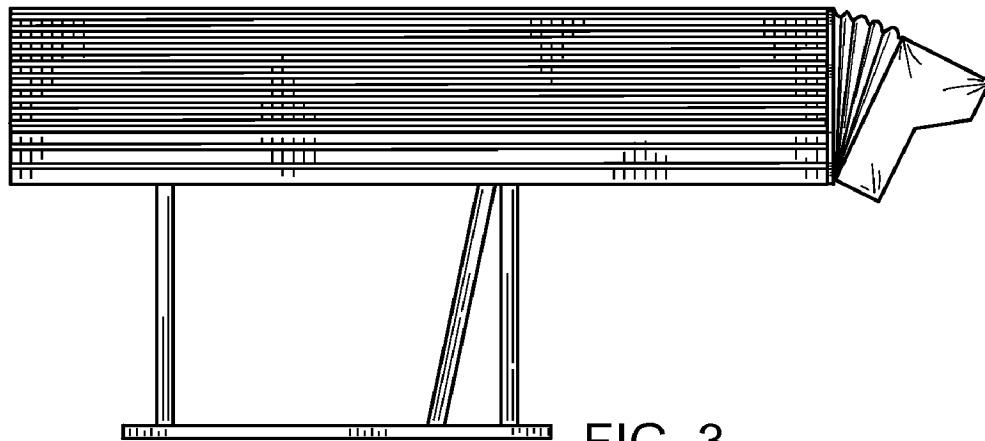

FIG. 3

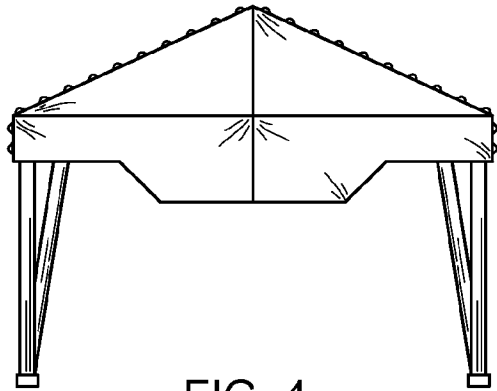

FIG. 4

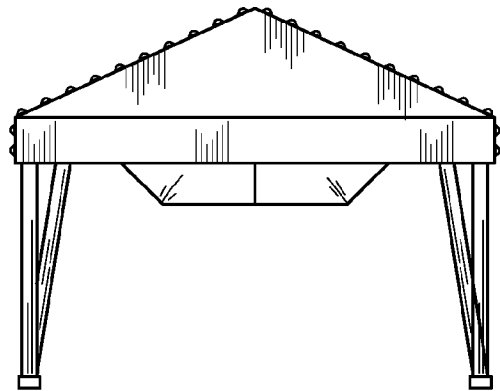

FIG. 5

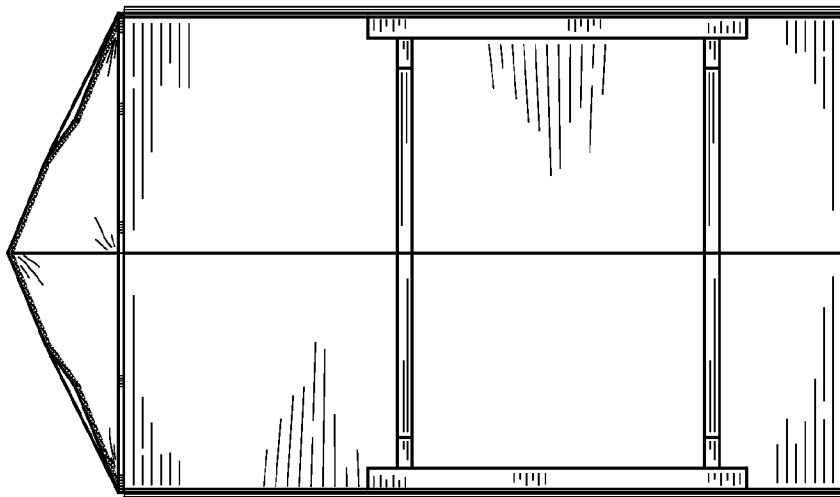

FIG. 6

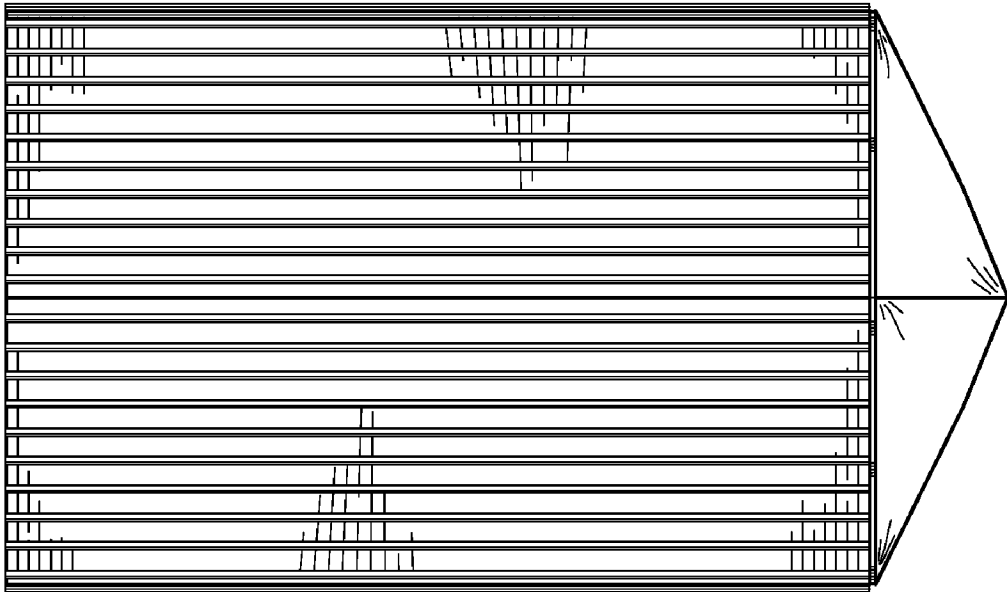

FIG. 7

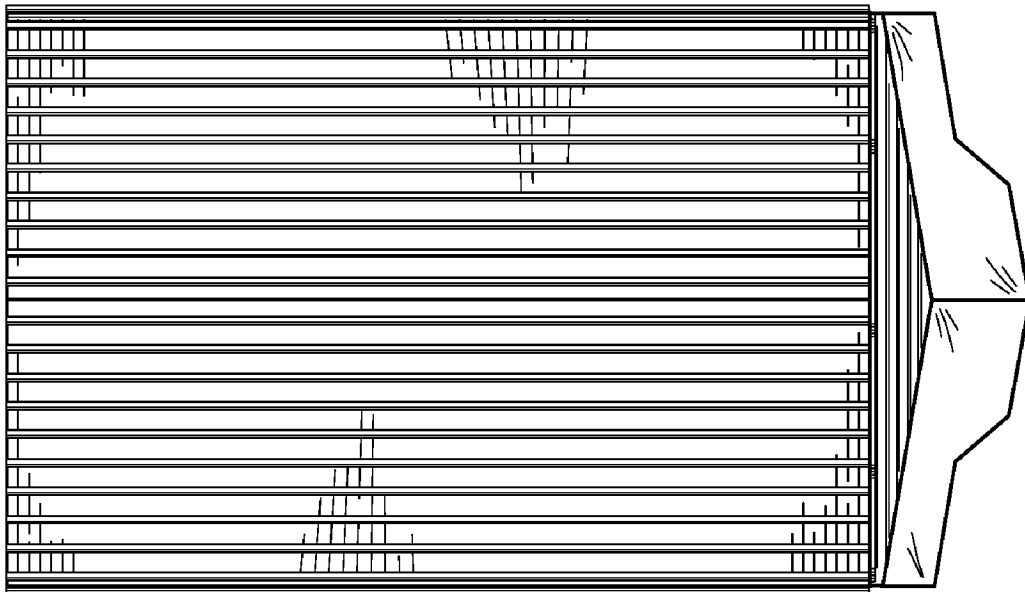

FIG. 8